



EDP 16-C/20



STÖCKLIN – YOUR ADVANTAGES

Compact and easy to handle

- Higher productivity
- Ideal handling
- High degree of flexibility

Modern electronic control

- A.C. drive motor with CAN BUS technology 
- Safe handling even on slopes
- Smooth transport of materials and reduced vehicle wear
- Optimum response at all times
- Power saving
- Emergency driving system

Sturdy Swiss Quality

- Best quality and long service life
- High serviceability
- Best value for money
- Reasonable spare part prices

DRIVE

Maintenance-free, smooth-running three-phase AC motor with high torque at lowest speed.

Charging during electronic brake application. The centre drive with two lateral spring mounted and damped support rollers ensures high stability and optimum traction in materials handling. All wheels (load rollers inclusive) made of durable Vulkollan.

ELECTRONIC SYSTEM

User-programmable microprocessor controller. COMBINED drive and lift control. The AC travel drive and the variable-speed DC hoisting motor are energy-saving. The standard initial lift stop protects the powerful hydraulic unit and the valves. CAN BUS technology with best screening. The LOS (Limited Operating Strategy) system allows limited travel motion in case of failures that cause a standstill. The operational response and other parameters can be easily adapted to the customer's individual requirements by means of a manual programming device.

DIMENSIONS

Constructed using the latest in 3D computer aided design, it is extremely compact.

What it lacks in size is made up for in serviceability. The removable protective cover facilitates the maintenance and adjustment.

ERGONOMICS AND SAFETY

The centred steering handle provides more agility due to a maximum of freedom of movement.

The ergonomically designed tiller allows for a precise handling even with working gloves on both hands. Handling in narrow spaces even with vertical steering handle due to the additional bridging switch.

STRUCTURE AND EQUIPMENT

Developed from a new complex modular system with multiple use of standard components. Very rugged despite its compact design. Axle and bolts of the load wheels and the hoisting gear made of stainless steel. EMERGENCY STOP button, combined working hours meter, battery controller with error code indicator. Built-in charger 30A/230V. Battery 24V – 250 Ah.

Options:

- Other battery sizes
- Battery change from the side
- Protective grid
- More resistant support rollers
- Client-specific load parts
- Available in cold store version

Stocklin

EDP 16-C/20

TECHNICAL DATA

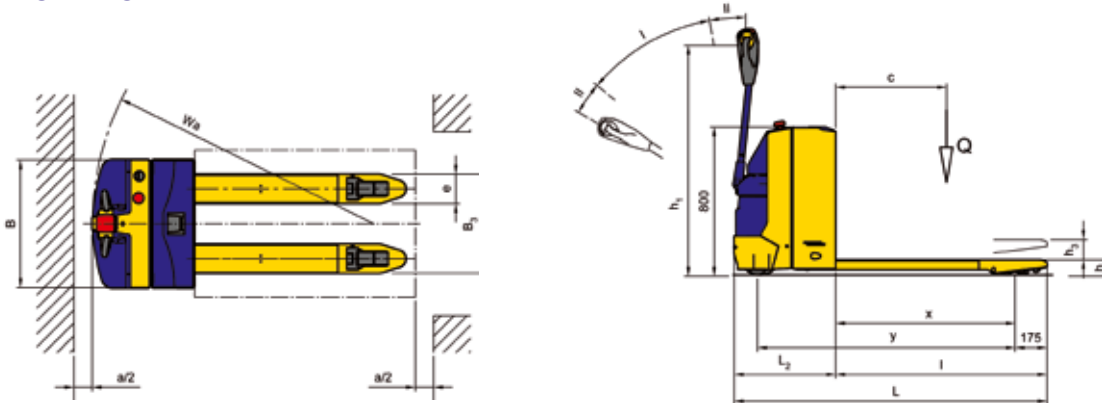

1.2	Model		EDP 16-C	EDP 20
Performance data				
1.5	Load capacity/Initial lifting load	Q[kg]	1600	2000
1.6	Distance to centre of gravity of load	c[mm]	600	
5.1	Top speed with/without load	[km/h]	5,5/5,5	
5.2	Lifting speed with/without load	[m/s]	0,04/0,05	
5.3	Lowering speed with/without load	[m/s]	0,05/0,04	
5.8	Max. gradient with/without load	[%]	10,0/17,0	
Dimensions				
1.8	Load distance	x [mm]	975	
1.9	Wheel base	y [mm]	1345	1385
4.4	Initial lifting	h3 [mm]	120	
4.9	Height min./max. steering handle in use	h1 [mm]	760/1290	
4.15	Forks lowered	h [mm]	85	
4.19	Overall length	L [mm]	1660	1700
4.20	Length of front pad	L2 [mm]	510	550
4.21	Overall width	B [mm]	700	
4.22	Dimensions of forks	s/e/l [mm]	55/160/1150	
4.25	Distance between outer edge of forks	B3 [mm]	540	
4.32	Floor clearance in lowered position	m2 [mm]	30	
4.34	Width pallet service zone (800x1200) VDI3597	branche [mm]	1915	1955
	Safety Distance	a/2 [mm]	100	
4.35	Turning radius	Wa [mm]	1490	1530

			EDP 16-C	EDP 20
Weight				
2.1	Weight of vehicle with battery	[kg]	505	555
2.2	Weight on front/rear axle with load	[kg]	827/1278	962/1593
2.3	Weight on front/rear axle without load	[kg]	380/125	420/135
Wheels				
3.1	Tyres of all wheels		Vulkollan	
3.2	Drive wheel		1x230/70	
	Type of drive/steering handle		centred/centred	
3.3	Load rollers		2x83/90	
3.4	Support rollers		2x100/40	
Drive and control				
6.1	Driving motor A.C.	[kW]	1,2	
6.2	Lifting motor D.C.	[kW]	1,2	
8.1	Driving control	combined [A]	200	
5.10	Driving brake		motor/counter current	
	Parking brake, electro-mechanical	[Nm]	11	
Battery				
6.3	Type of battery		PPV-BS	PPV-DIN
6.4	Battery voltage, capacity*	[V/Ah]	24/160	24/250
	Battery designation		2EPzBS160	2EPzS250

*Batteries up to L₂+70mm
Subject to technical modifications.

Stöcklin, or one of our partners in your region, will be pleased to advise you.

Stöcklin

Stöcklin Logistik AG
Materials Handling and Storage Systems
CH-4143 Dornach
Tel. +41 (0) 61 705 81 11
Fax +41 (0) 61 705 82 25
E-Mail unit-f@stoeklin.com
www.stoeklin.com

SWISS MADE / ISO 9001